

### 13. Surface chemistry of polymers

#### The adsorption of carbon dioxide and sulfur dioxide on polyvinylidene chloride

by H. F. Stoeckli

Institut de chimie de l'Université, Université de Neuchâtel

(23. XI. 71)

*Summary.* Isotherms for the adsorption of nitrogen (77 K), carbon dioxide (195–247 K) and sulfur dioxide (254–293 K) on polyvinylidene chloride have been measured volumetrically. The *B. E. T.* cross-sectional areas of 18 Å<sup>2</sup> (CO<sub>2</sub>) and 24 Å<sup>2</sup> (SO<sub>2</sub>) are comparable to liquid density values. The isosteric heat of adsorption of CO<sub>2</sub> is constant for 0.2 <  $\theta$  < 0.4 and is lower than the latent heat of condensation. For SO<sub>2</sub>, the two are practically identical up to the monolayer. Entropy calculations show 'supermobility' in the case of CO<sub>2</sub>.

**Introduction.** – Polyvinylidene chloride has already been investigated by *Hall & Stoeckli* [1] who found that it has a fairly homogenous surface of low energy. It was shown that the heat of adsorption for the spherical neopentane was slightly higher than its heat of condensation, whereas the linear butane had a much lower (relative) heat of adsorption. The difference between the hydrocarbons was explained in terms of surface accommodation. Entropy calculations for butane showed 'supermobility', involving some retention of the translational entropy as a vibration normal to the surface.

A similar situation is now described for the pair CO<sub>2</sub>/SO<sub>2</sub>.

**Experimental.** – A conventional volumetric apparatus, shown in Fig. 1 was used.

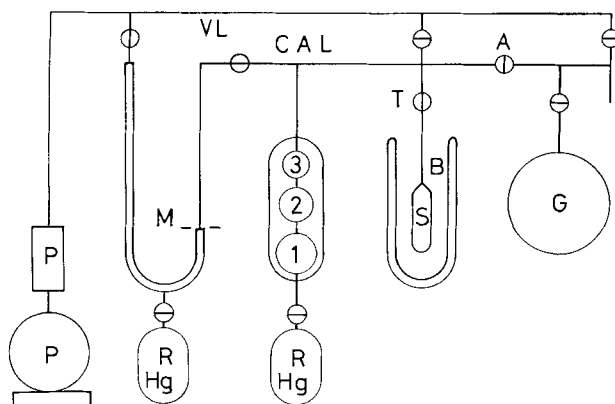

Fig. 1. Schematic representation of the volumetric apparatus (not to scale)

The powdered solid under investigation (2 g) is kept in the sample holder S, surrounded by a constant temperature bath B. Outgassing occurs *via* the vacuum line VL and combined rotary and mercury diffusion pumps P, operating at 10<sup>-6</sup> Torr. The sample was outgassed at room temperature, initially for 10 h, and for 3–5 h between successive runs. No permanent retention was detected.

The successive amounts of gas ( $4\text{--}10 \cdot 10^{-5}$  mol) added to the system through tap A from globe G (tap T closed), were measured volumetrically in the calibrated section CAL with a constant volume manometer M. Readings were taken with a cathetometer accurate to 0.1 mm. The volume CAL could be varied from 60 to 10 cm<sup>3</sup> by filling the three thermostatted and calibrated bulbs with mercury from a reservoir R. The optimum value was near 30 cm<sup>3</sup>, where  $n_a$ , the amount of gas adsorbed was always of the same order ( $2\text{--}40 \cdot 10^{-5}$  mol) as  $n_g$ , the amount present in the gas phase (CAL + dead space in S).

When tap T is opened and the adsorption equilibrium is reached (10–30 min), the quantity adsorbed on the solid, at pressure  $p$ , is given by the difference  $n_a = n_t - n_g$ , where  $n_t$  is the total amount of adsorbate added. The total error in  $n_a$  is about 3% over the pressure range investigated (20–400 Torr). For the final calculations,  $N_a$  is used. It represents the adsorption per g of solid. The ideal gas equation is sufficient to compute  $n_a$ , because the use of the second virial coefficient has little influence on the difference ( $n_t - n_g$ ). The second virial coefficient is however used for dead space calibrations in the apparatus.

The constant temperature bath B contained either liquid nitrogen, solid CO<sub>2</sub>, mixtures of water and methanol, or water/ice.

Polyvinylidene chloride (PVDC) came from the same batch as used previously [1] (*The Dow Chemical Co.*) and had a surface area of 24 m<sup>2</sup>/g. This value was checked with oxygen-free nitrogen. Carbon dioxide, of industrial origin, was purified by successive condensations and evaporations between 77 and 195 K.

Sulfur dioxide obtained from *Fluka AG* in a stated purity of 99.97% was passed through a cold trap before being stored in globe G.

**Theoretical background.** – Physical adsorption can be treated by the so-called *B.E.T.* theory, within the limits discussed by *Gregg & Sing* [2]. The final expression for the adsorption is

$$p/N_a \cdot (p_0 - p) = 1/N_m \cdot c + (c - 1) \cdot (p/p_0)/N_m \cdot c \quad (1)$$

where  $p_0$  is the saturation pressure of the gas at temperature  $T$ ,  $N_m$  the monolayer capacity of the surface (mol/g of solid),  $p$  the pressure at which the amount  $N_a$  is adsorbed, and  $c$  a parameter of the theory.

If relation (1) holds a graphical representation of  $p/N_a(p_0 - p)$  versus  $p/p_0$  (*B.E.T.* plot), it should give a straight line within the region  $0.05 < p/p_0 < 0.35$ . From the slope and intercept it is possible to compute  $N_m$  by elimination of  $c$ . The surface  $S$  of the solid and the cross-sectional area of the adsorbate  $A_m$  are related by

$$S = N \cdot A_m \cdot N_m \quad (N = \text{Avogadro's number}). \quad (2)$$

The usual standard is nitrogen, for which  $A_m = 16.2 \cdot 10^{-20}$  m<sup>2</sup>.

There are different *heats of adsorption* and these have been examined by *Ross & Oliver* [3]; however we shall use an isosteric heat of adsorption  $Q^{\text{st}}$  defined as follows.

For a gas in equilibrium with an adsorbed phase of area  $A$  and spreading pressure  $\pi$ , we have [3]

$${}_gV \, dp - {}_gS \, dT + {}_g\mu \, dN_g = {}_aV \, dp - {}_aS \, dT + {}_a\mu \, dN_a + A \, d\pi. \quad (3)$$

For a constant amount adsorbed (coverage  $\theta = N_a/N_m$  cte)

$${}_gV \, dp - {}_gS \, dT = {}_aV \, dp - {}_aS \, dT + A \, d\pi. \quad (4)$$

If we consider adsorption as the final state,

$$\begin{aligned} ({}_aV - {}_gV) \, dp &= ({}_aS - {}_gS) \, dT - A \, d\pi, \\ (\partial p / \partial T)_\theta &= ({}_aS - {}_gS) / ({}_aV - {}_gV) - A (\partial \pi / \partial T) / ({}_aV - {}_gV). \end{aligned}$$

With  ${}_aV \ll {}_gV$  and  ${}_gV = RT/p$ ,

$$\begin{aligned}(\partial p/\partial T)_\theta &= -({}_aS - {}_gS)(p/RT) + (A p/RT)(\partial\pi/\partial T)_\theta, \\(\partial \ln p/\partial T)_\theta &= -[({}_aH - {}_gH)/RT^2 - (A/RT)(\partial\pi/\partial T)_\theta], \\(\partial \ln p/\partial T)_\theta &= -Q^{\text{st}}/RT^2,\end{aligned}\tag{6}$$

where

$$Q^{\text{st}} = \Delta H_{\text{ads}} - AT(\partial\pi/\partial T)_\theta \text{ and}\tag{7}$$

$$\Delta H_{\text{ads}} = {}_aH(T, p, \theta) - {}_gH(T, p).\tag{8}$$

The integration of equation (6) leads to

$$\ln(p_2/p_1)_\theta = (Q^{\text{st}}/R)(1/T_2 - 1/T_1).\tag{9}$$

Since  $(p_2 > p_1)$  for  $(T_2 > T_1)$ ,  $Q^{\text{st}}$  obtained from two isotherms is a negative quantity, in agreement with the process of adsorption. The quantity

$$q^{\text{st}} = {}_gH - {}_aH + AT(\partial\pi/\partial T)_\theta,\tag{10}$$

which is commonly used [3], is also called the isosteric heat of adsorption. It is however a positive quantity and hence should rather be called the heat of *desorption*.

It should also be pointed out, that the enthalpy of adsorption  $\Delta H_{\text{ads}}$  of relations (7) and (8) is the quantity which should be compared with  $\Delta H_{\text{liq}}$ , rather than  $Q^{\text{st}}$ . The two are not necessarily equal [3].

Given two isotherms, we may write, according to Gregg [5]

$$\begin{aligned}\Delta G_{\theta, T_1} &= RT_1 \ln(p_1/1 \text{ atm}) = \Delta H_\theta - T_1 \Delta S_\theta, \\ \Delta G_{\theta, T_2} &= RT_2 \ln(p_2/1 \text{ atm}) = \Delta H_\theta - T_2 \Delta S_\theta.\end{aligned}\tag{11}$$

One obtains  $\Delta H_\theta$  and  $\Delta S_\theta$  (implicitly assumed to be temperature-independent), corresponding to the adsorption from the gas at 1 atm to a coverage  $\theta$  of the surface.

$$\Delta H_\theta \approx \Delta H_{\text{ads}}.$$

For the *entropy of adsorption*, it is convenient to use *de Boer's* method [4] described by Gregg [5].

From equation (11) one obtains (12).

$$\Delta S_\theta(\text{exp}) = R[T_1 \ln(p_1)_\theta - T_2 \ln(p_2)_\theta]/(T_2 - T_1).\tag{12}$$

If the model of mobile adsorption (two-dimensional gas) is considered, it is customary to correct the entropy change given by (12) to a standard surface state, where the distance between the adsorbed molecules is the same as in the gas at  $p = 1$  atm (also a standard state). Relation (12) becomes (13) where  $A_0$  is the standard area, and  $A$  the area occupied by an adsorbed molecule at coverage  $\theta$ .

$$\Delta S_\theta^0(\text{exp}) = \Delta S_\theta(\text{exp}) + R \ln(A_0/A)\tag{13}$$

For the loss of one translational degree of freedom on adsorption under standard conditions, statistical mechanics give

$$\begin{aligned}\Delta S_{\text{mob}}^0(\text{theor.}) &= {}_aS_{\text{tr}}^0 - {}_gS_{\text{tr}}^0 \\ &= -\frac{1}{2}(R \cdot \ln M + R \cdot \ln T + 4.60).\end{aligned}\tag{14}$$

There also exists a model for localised adsorption.

**Results and discussion.** - Nitrogen was adsorbed at 77 K, before and after the present set of experiments, in order to test the new apparatus and to check the state of the surface under investigation. The results are shown in Fig. 2, together with earlier measurements obtained gravimetrically at 78 K [1] (Exeter 1969).

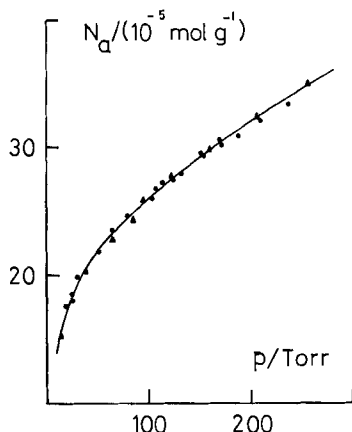

Fig. 2. Isotherm for the adsorption of nitrogen on PVDC at 77 K (●) and 78 K (▲, Exeter 1969, gravimetrically)

They are all on the same isotherm, which means that the surface of PVDC is the same throughout the present work (24 m<sup>2</sup>/g), and that no change was caused by the gases used (especially SO<sub>2</sub>).

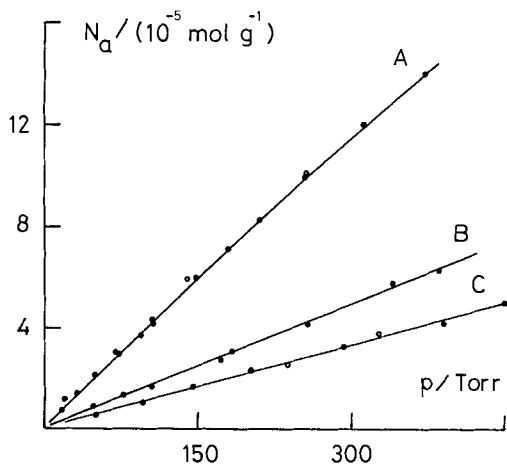

Fig. 3. Isotherms for the adsorption of CO<sub>2</sub> on PVDC at 195 K (A), 227 K (B) and 247 K (C)

Carbon dioxide was adsorbed at 195, 227 and 247 K. The isotherms shown in Fig. 3 are practically linear in the range investigated. Such isotherms have already been reported for the adsorption of CO<sub>2</sub> on porous alumina by Clough & Harris [6], and on graphon by Brousse & Lespinasse [7].

The isotherm for 195 K gives a good *B.E.T.* plot, and the value of  $(18 \pm 1) \text{ \AA}^2$  obtained for  $A_m$  can be compared with  $17 \text{ \AA}^2$ , the value from the density of liquid  $\text{CO}_2$  at 216 K (the triple point). It represents an average for the non-spherical molecule, since values quoted in the survey of *McClellan & Harnsberger* [8] range from 14 to  $25 \text{ \AA}^2$ .

The isosteric heats of adsorption derived from the three isotherms are self-consistent, and constant. For the average temperature  $\bar{T} = 216 \text{ K}$ ,  $-Q^{\text{st}} = (10.5 \pm 0.5) \text{ kJ/mol}$  for  $0.2 < \theta < 0.4$ . This value is smaller than the heat of vaporisation at 217 K ( $16.20 \text{ kJ/mol}$ ) measured by *Haas & Barnes* [9]. The enthalpy of adsorption defined in equations (11) is found to be about  $-9.8 \text{ kJ/mol}$ , which is smaller than  $Q^{\text{st}}$ .

The linearity of the isotherm [5] and the low heats of adsorption already suggest mobile adsorption for  $\text{CO}_2$ ; this is confirmed by entropy calculations (see below).

*Sulfur dioxide* was adsorbed at 254, 273 and 293 K, and the corresponding isotherms are shown in Fig. 4. They are of a smooth type II. The *B.E.T.* plot for 273 K is good

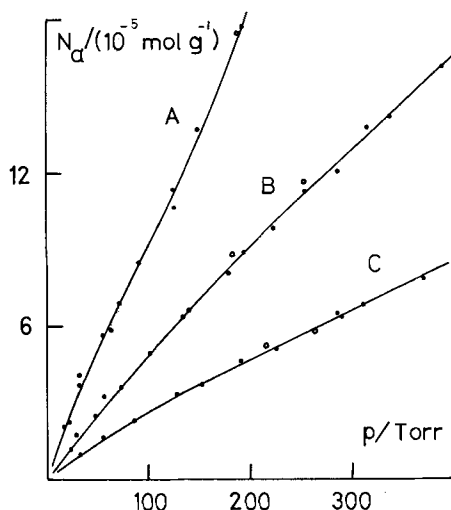

Fig. 4. Isotherms for the adsorption of  $\text{SO}_2$  on PVDC at 254 K (A), 273 K (B) and 293 K (C)

and yields the value of  $(24 \pm 1) \text{ \AA}^2$  for  $A_m$ , against  $19 \text{ \AA}^2$  from the density of the liquid at the same temperature. The range covered by the measurements extends to the monolayer region. The isosteric heats of adsorption derived from the three isotherms are consistent and give a *constant* value for  $0.2 < \theta < 1$ . The average value of  $Q^{\text{st}} = -(23 \pm 1.5) \text{ kJ/mol}$  at  $\bar{T} = 273 \text{ K}$ , is practically equal to the heat of liquefaction at this temperature ( $-24.06 \text{ kJ/mol}$ ) [10]. In the range of temperature 254–293 K, the variation of this quantity from  $-25.5$  to  $-22.2 \text{ kJ/mol}$  is consistent with the limits for  $Q^{\text{st}}$  given above.

The enthalpy change on adsorption of  $\Delta H_{\text{ads}} \simeq -21 \text{ kJ/mol}$  is smaller than  $Q^{\text{st}}$  and illustrates the point raised earlier.

*Comparison of experimental and theoretical entropy changes on adsorption,  
according to relations (12), (13) and (14)*

Coverage	$[-\Delta S_{\theta}(\text{exp})]$	$-\Delta S_{\text{mob}}^0(\text{exp})$	$-\Delta S_{\text{mob}}^0(\text{theor})/(\text{J mol}^{-1}\text{K}^{-1})$
		CO <sub>2</sub> ( $\bar{T} = 210 \text{ K}$ )	
0.20	38	19	
0.30	41	19	40.1
0.40	42	18	
		SO <sub>2</sub> ( $\bar{T} = 263 \text{ K}$ )	
0.20	64	49	
0.40	63	40	
0.60	65	38	
0.70	67	38	42.6
0.80	70	40	
0.90	74	43	

Entropy calculations based on the model of mobile adsorption are shown in the Table. (The model for localised adsorption [5] is not given, because it gave discrepancies of 60–80 J/mol K.)

For sulfur dioxide, the standard loss of entropy at  $\bar{T} = 263 \text{ K}$  is close to the value expected from the model.

Carbon dioxide, on the other hand, shows 'supermobility', a feature already observed for butane on PVDC [1]. This means that the entropy loss on adsorption is less than predicted for the loss of one translational degree of freedom, assuming that the adsorbed film behaves like a two-dimensional gas. The vibrational contribution would be approximately +21 J/mol K, compared to 23 J/mol K for butane. Since both molecules also have relatively low heats of adsorption, their behaviour on the PVDC surface must be very similar.

Acknowledgements are due to Mr. C. Maneff for technical assistance.

#### BIBLIOGRAPHY

- [1] P. G. Hall & H. F. Stoekli, *Trans. Faraday Soc.* **65**, 3334 (1969).
- [2] S. J. Gregg & K. S. W. Sing, 'Adsorption, Surface and Porosity', Academic Press, London 1967.
- [3] S. Ross & J.-P. Olivier, 'On Physical Adsorption', Chapters 2, 3 and 5, Interscience, New York 1964.
- [4] J. H. de Boer, 'The Dynamical Character of Adsorption', Chapter 6, Clarendon Press, Oxford 1953.
- [5] S. J. Gregg, 'The Surface Chemistry of Solids', Chapter 2, Chapman & Hall, London 1965.
- [6] P. S. Clough & M. R. Harris, *Chemistry & Ind.* **1968**, 343.
- [7] E. Brousse & B. Lespinasse, *J. Chimie physique* **67**, 1782 (1970).
- [8] A. L. McClellan & H. F. Harnsberger, *J. Colloid Interface Sci.* **23**, 577 (1967).
- [9] O. Haas & W. H. Barnes, *Proc. Royal Soc. A* **111**, 234 (1926).
- [10] 'The Handbook of Chemistry and Physics', The Chemical Rubber Co, Cleveland 1970.